



# A FE model updating technique based on SAP2000-OAPI and enhanced SOS algorithm for damage assessment of full-scale structures

D. Dinh-Cong<sup>a,c</sup>, T. Nguyen-Thoi<sup>b,c,\*</sup>, Duc T. Nguyen<sup>d</sup>

<sup>a</sup> Division of Construction Computation, Institute for Computational Science, Ton Duc Thang University, Ho Chi Minh City, Viet Nam

<sup>b</sup> Division of Computational Mathematics and Engineering, Institute for Computational Science, Ton Duc Thang University, Ho Chi Minh City, Viet Nam

<sup>c</sup> Faculty of Civil Engineering, Ton Duc Thang University, Ho Chi Minh City, Viet Nam

<sup>d</sup> Department of Civil and Environmental, Old Dominion University, 135 Kaufman Hall, Norfolk, VA 23529, USA

## ARTICLE INFO

### Article history:

Received 25 April 2019

Received in revised form 4 November 2019

Accepted 13 January 2020

Available online 20 January 2020

### Keywords:

Damage assessment

Damage detection

Model updating

SAP2000

Symbiotic organisms search (SOS)

Full-scale structures

## ABSTRACT

Although many existing damage diagnosis techniques based on the combination of optimization algorithms and finite element model updating have been studied and demonstrated to be promising, there are still some limitations that need to be improved to enhance their performance for the large and complex structures. In this regard, the present article proposes a FE model updating technique based on the existing commercial software SAP2000-OAPI and an enhanced symbiotic organisms search (ESOS) algorithm for damage assessment of full-scale structures. First, to overcome the complexities of FE simulation, the FE model of monitored structure is built in SAP2000 software for analyzing the dynamic behavior of the structure. Then, the damage assessment of the structure is set up in the form of an optimization problem in which the objective function is established based on a combination of flexibility matrix and modal assurance criterion (MAC). An improved version of SOS algorithm, called ESOS algorithm, is adopted to solve this optimization problem for detecting and quantifying any stiffness degradation induced by damage. To perform the iterative optimization task automatically, a link between MATLAB and SAP2000 is created by using the OAPI feature of SAP2000. Finally, the numerical investigations on two full-scale structures with considering measurement noise and sparse measured data demonstrate the feasibility of the proposed technique in predicting the actual damage sites and their severities.

© 2020 Elsevier B.V. All rights reserved.

## 1. Introduction

With the general goal of maintaining civil and mechanical engineering structures safely and efficiently, a considerable amount of effort has been devoted to the development of structural health monitoring (SHM) systems during the last few decades [1,2]. In an SHM system, predicting the location and the magnitude of structural damage is one of the most fundamental tasks. Thus, a great deal of attention has been paid to researchers on innovative technologies and techniques for structural damage localization and quantification. Among all available strategies, vibration-based damage diagnosis (VBDD) techniques have been considered as the most attractive ones [3–5]. These VBDD techniques can be roughly classified into two categories: non-model (data-driven) based methods and model-based methods. The non-model-based

methods, without using structural analytical programs, are able to localize the structural damage efficiently but they are difficult to achieve the damage severity estimation with a relatively high level of accuracy. On the contrary, the model-based methods requiring a numerical model (i.e., finite element (FE) model) are more effective to identify both the damage location and its extent [6,7].

Basically, a set of model-based fault detection approaches is usually developed using FE models and model updating strategies to provide an effective manner for structural damage tracking. In this manner, a FE model is employed to analyze and simulate the actual behavior of structural system under different conditions, and then the process of updating model's parameters is iteratively adjusted to correlate measured and predicted response data. Once the correlation achieves a good agreement, the selected updating parameters would serve as damage indicators. Compared with many other available strategies, intelligent optimization methods have been more widely used for the FE model updating process [8]. Over the past decade, various meta-heuristic optimization algorithms have shown remarkable success in solving

\* Correspondence to: Institute for Computational Science, Ton Duc Thang University, Ho Chi Minh City, Viet Nam.

E-mail addresses: [dinhcongdu@tdtu.edu.vn](mailto:dinhcongdu@tdtu.edu.vn) (D. Dinh-Cong), [nguyenthotrung@tdtu.edu.vn](mailto:nguyenthotrung@tdtu.edu.vn) (T. Nguyen-Thoi), [dnguyen@odu.edu](mailto:dnguyen@odu.edu) (D.T. Nguyen).

the model updating-based damage detection problem, such as teaching-learning-based optimization (TLBO) algorithm [7,9], Jaya algorithm [10], lightning attachment procedure optimization (LAPO) algorithm [11], and several improved/ hybrid optimization algorithms [12–15]. For a more detailed summary of this subject, interested readers may refer to meticulous literature reviews [8,16]. Although many existing damage diagnosis techniques [8] based on the combination of optimization algorithms and FE model updating have been studied and demonstrated to be promising, there are still some issues that need to be improved more thoroughly as follows:

- (i) Structural FE analysis in computational programs like MATLAB may be restricted to the ability to simulate the actual behavior of large and complex structures because of modeling simplifications [17], which may lead to an incorrect damage prediction. In addition to this, the development of the FE model in MATLAB program for analysis of full-scale structures is usually expensive and time-consuming, or even impossible. Accordingly, a majority of the existing techniques in the literature still focused on relatively small and simple structures.
- (ii) Another challenge is the use of incomplete measurements and noise-polluted measured data for damage localization and quantification due to instrumentation cost and measurement conditions, which leads to increase ill-posedness for the updating process [18]. Effectively accounting for this challenge is therefore an important undertaking.
- (iii) The performance of the updating process mainly depends on the strength of optimization algorithm selected to update the model's parameters [8]. In this viewpoint, powerful and reliable optimization algorithms should be developed and applied with the aim of decreasing the computational cost and producing accurate and reliable damage prediction.

Among a large number of newly proposed metaheuristic optimization algorithms, symbiotic organisms search (SOS) algorithm [19] has received increasing attention from the community of researchers dealing with optimization problems due to its implementation efficiency and stability. The SOS algorithm, a novel population-based optimization algorithm, takes inspiration from the interactive relationship between organisms in nature. It was originally designed for continuous optimization problems and its results showed superior performance in comparison with other well-known meta-heuristic algorithms (i.e., genetic algorithm (GA), particle swarm optimization (PSO), differential evolution (DE), and cuckoo search (CS)). Since then, the SOS algorithm and its modified versions have been successfully applied to different types of optimization problems, such as electronic engineering [20,21], economic dispatch [22,23], engineering structures [24–26], design of antenna arrays [27,28], and other engineering applications [29–31]. According to some recent review articles [32–34], it is concluded that the areas of application and performance of the SOS algorithm are constantly being broadened and improved. Until now, however, very little work used the algorithm and/or its modified versions are reported in the field of damage diagnosis of structures. In our recent study [26], we applied the standard SOS algorithm for solving the damage assessment problem of 2D frame and truss structures and its results revealed that this algorithm is very promising for the field. In the present research, the enhanced symbiotic organisms search (ESOS) [35] algorithm is exploited to further improve the performance of the original SOS algorithm for damage identification of full-scale structures.

With the rapid development of modern computational technologies, commercial FE modeling software packages have been

well developed and becoming powerful tools in engineering applications. These software packages not only are capable of analyzing large and complicated structural systems more accurately and conveniently but also allow users to link them with third-party software (e.g., MATLAB). By taking these advantages, optimization-based FE model updating techniques in conjunction with commercially available FE software packages have been recently proposed by a few researchers in the field of structural damage identification. For instance, Sanayei and Rohela [36] developed a parameter identification system (PARIS) program that is utilized as an available Optimization Toolbox coded in MATLAB interacting with FE analysis solver of SAP2000 software via Open Application Programming Interface (OAPI), for automated FE model updating of full-scale structures. The PARIS program showed its feasibility for model calibration and impairment identification purposes. Nevertheless, this program was not focused on identifying elements individually of the monitored structure but on each group including a large number of elements. Nozari et al. [37] presented a FE model updating framework by combining gradient-based least-squares optimization approach and SAP2000 software for modal identification and damage detection of a 10-story building using ambient vibration measurements. In their proposed framework, however, only a small number of updating parameters (12 parameters) were considered in the optimization process. As found in the literature, there is very little work that used the integration of a commercial software package with a powerful and reliable optimization algorithm for structural damage localization and quantitation. Thus, additional research efforts are necessary to develop new FE model updating techniques that can effectively address the above-mentioned challenges.

In the present work, a FE model updating technique based on existing commercial software SAP2000-OAPI and ESOS algorithm is proposed for damage assessment of full-scale structures. First, to overcome the complexities of FE simulation, a SAP2000 model of the monitored structure is utilized for analyzing the dynamic behavior of the structure. By using structural vibration parameters (e.g., natural frequencies and corresponding mode shapes) extracted from the SAP2000 model, the ESOS algorithm is adopted to minimize an objective function that is formulated based on a combination of flexibility matrix and modal assurance criterion (MAC). Herein, the ESOS algorithm, an improved version of the original SOS algorithm to reduce the computational cost, is coded in MATLAB interacting with SAP2000 through OAPI feature for two-way data exchange. Finally, the effectiveness and robustness of the proposed FE model updating technique are investigated through two numerical examples including an industrial steel frame and a 3D two-story full-scale building with various possible damage scenarios. In addition, the simultaneous effect of measurement noise and sparse measured data on the proposed technique is also taken into account.

The remainder of this article is structured as follows. Section 2 presents the statement of optimization-based damage diagnosis problem using SAP2000-OAPI, whereas Section 3 provides an introduction to SOS and enhanced SOS algorithms. In Section 4, the numerical results and performance evaluation of the proposed damage identification technique are discussed. Lastly, we highlight some important concluding remarks in Section 5.

## 2. Statement of FE model updating problem using SAP2000-OAPI

The FE model updating problem is an inverse problem whose the solution can predict both damage site and damage magnitude.

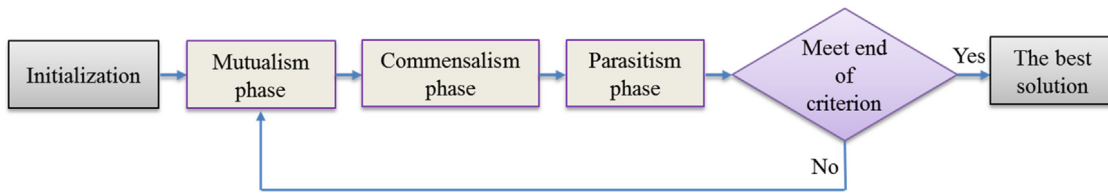

Fig. 1. Flow chart of SOS algorithm.

This problem can be treated and solved as an optimization task that is mathematically posed as

$$\begin{aligned} & \text{finding } \mathbf{x} = x_1, x_2, \dots, x_n \\ & \text{Minimize } \Gamma(\mathbf{x}) \\ & \text{S.t. } 0 \leq x_i \leq 1, i = 1, 2, \dots, n \end{aligned} \quad (1)$$

where  $x_i$ , the  $i$ th component of  $n$  design variables, is the location and degree of damage of suspected elements;  $\Gamma(\mathbf{x})$  is the objective function.

As shown in Eq. (1), the damage detection process is achieved by minimizing an objective function that can be defined based on the discrepancy between experimental modal parameters and the corresponding analytical predictions. The objective function plays an important role in the successful updating of structural model parameters. Although there are various objective functions available in the literature [8,16], it is difficult to find a clear criterion for choosing a proper objective function [38]. Among the modal parameters, mode shape, and modal flexibility are the most common parameters used to construct an objective function for tracking damage. In the present study, a modal flexibility-based residual is incorporated with a modal assurance criterion (MAC)-based residual to generate an expected combined objective function. The two forms of the residuals are given as follows

$$F_k(\mathbf{x}) = \left( \frac{\|\mathbf{F}_k^d - \mathbf{F}_k^c(\mathbf{x})\|_{Fro}}{\|\mathbf{F}_k^d\|_{Fro}} \right)^2 \quad (2)$$

$$MAC_r(\mathbf{x}) = \frac{|\left(\Phi_r^d\right)^T \Phi_r^c(\mathbf{x})|^2}{\left(\left(\Phi_r^d\right)^T \Phi_r^d\right) \left(\left(\Phi_r^c(\mathbf{x})\right)^T \Phi_r^c(\mathbf{x})\right)} \quad (3)$$

where  $\mathbf{F}_k^d$  and  $\mathbf{F}_k^c$  are, respectively, the  $k$ th column of the flexibility matrix obtained from the damaged structure and the FE analytical model;  $\|\cdot\|_{Fro}$  denotes the Frobenius norm of a matrix;  $\Phi_r^d$  and  $\Phi_r^c$  are, respectively, the  $r$ th mode shape vector obtained from the damaged structure and the FE analytical model. Based on the residuals, the combined objective function is expressed as

$$\Gamma(\mathbf{x}) = w_1 \frac{1}{nc} \sum_k F_k(\mathbf{x}) + w_2 \frac{1}{nmod} \sum_r \left(1 - \sqrt{MAC_r(\mathbf{x})}\right) \quad (4)$$

where  $nc$  denotes the total number of columns in the flexibility matrix;  $nmod$  denotes the number of considered mode vibrations;  $w_1$  and  $w_2$  are the weighting factors to the residuals. In general, the weighting factors reflect the relative importance of each residual, and their selection values are based on trial-and-error and/or engineering judgment.

For the purpose of finding the value of vector  $\mathbf{x}$  (design variable vector) of Eq. (4), a powerful and reliable optimization tool should be chosen to minimize the function  $\Gamma(\mathbf{x})$ . In each iteration of the updating process of vector  $\mathbf{x}$ , a SAP2000 model of the monitored structure is invoked as a slave program for FE analysis. Through OAPI feature, a link between MATLAB and SAP2000 is created to exchange two-way data. This allows performing the iterative optimization process automatically.

### 3. Introduction to SOS and enhanced SOS algorithms

#### 3.1. Standard SOS algorithm

SOS algorithm, which was first developed by Cheng and Prayogo [19], is a nature-inspired metaheuristic optimization algorithm. The distinctive advantage of this algorithm is that it uses only a few common controlling parameters (including maximum number of generations ( $G_{max}$ ), population size ( $Np$ ), and problem dimension ( $D$ )) and has no requirement of parameter fine-tuning or adjustments. The SOS algorithm mimics three fundamental symbiotic interaction strategies in the ecosystem, namely mutualism, commensalism, and parasitism. This algorithm is initialized by a population of organisms called an ecosystem, in which each member of the ecosystem can be considered as one candidate solution to the studied problem. Then, by simulating these interaction strategies between two members randomly, the next population is generated to improve their fitness in the ecosystem. The course of these symbiotic interactions is repeated until stopping criteria are reached. Fig. 1 illustrates the steps of the SOS algorithm, and the formulas for the four main steps including initialization, mutualism, commensalism, and parasitism phases are given as follows:

#### Initial parameters and ecosystem initialization:

In the first step, the input parameters of the SOS algorithm, such as  $D$ ,  $G_{max}$ , and  $Np$ , are specified. The group of initial organisms in the ecosystem is initialized by

$$X_{i,j} = X_j^l + rand * (X_j^u - X_j^l), \quad i = 1, 2, \dots, Np; \quad j = 1, 2, \dots, D \quad (5)$$

where  $rand$  is a random number between 0 and 1;  $X_j^l$  and  $X_j^u$  represent the lower and upper bounds of  $X_j$ , respectively;

#### The mutualism phase:

In the mutualism phase,  $X_i$  is the  $i$ th organism which randomly interacts with another organism  $X_k$  (where  $k \neq i$ ,  $k \in (1, 2, \dots, Np)$ ) to create new candidate organisms. The mutualistic interaction results in improving their fitness value as well as increasing their survival in the ecosystem, are given by Eqs. (6) and (7), respectively

$$X_i^{new} = X_i + rand * \left[ X_{best} - \left( \frac{X_i + X_k}{2} \right) * BF1 \right] \quad (6)$$

$$X_k^{new} = X_k + rand * \left[ X_{best} - \left( \frac{X_i + X_k}{2} \right) * BF2 \right] \quad (7)$$

where the term  $X_{best}$  denotes the best organism of the ecosystem at generation  $G$ ;  $BF$  is the beneficial factor and given by

$$\begin{aligned} BF1 &= 1 + round[rand] \\ BF2 &= 1 + round[rand] \end{aligned} \quad (8)$$

where  $round$  is utilized to set a beneficial factor ( $BF$ ) either 1 or 2.

After that, the selection operation is conducted by comparing the fitness function of two new candidate organisms ( $X_i^{new}$  and  $X_k^{new}$ ) with those of  $X_i$  and  $X_k$  organisms

$$X_i = \begin{cases} X_i & \text{if } \Gamma(X_i) \leq \Gamma(X_i^{new}) \\ X_i^{new} & \text{otherwise} \end{cases} \quad (9)$$

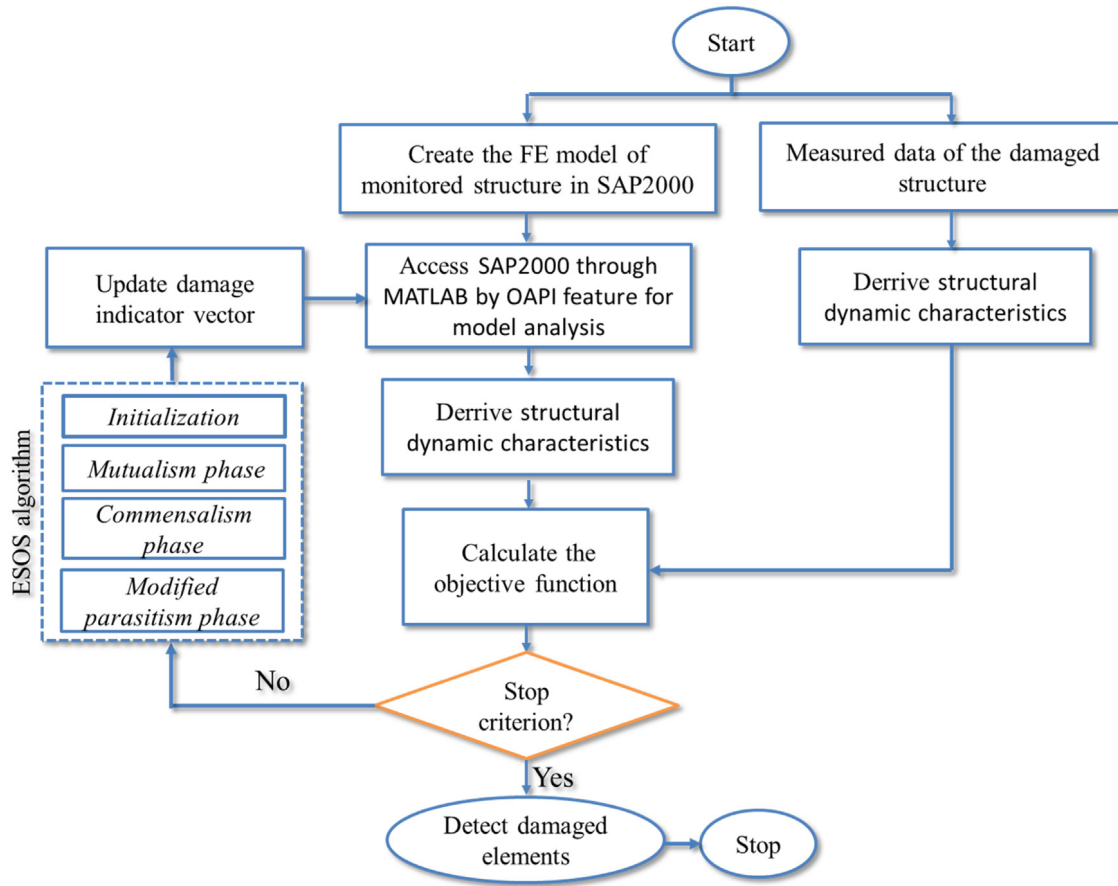

Fig. 2. The flowchart of the proposed FE model updating process..

$$X_k = \begin{cases} X_k & \text{if } \Gamma(X_k) \leq \Gamma(X_k^{new}) \\ X_k^{new} & \text{otherwise} \end{cases} \quad (10)$$

### 3.2. Enhanced SOS algorithm

Although the successful applications of the standard version of SOS algorithm have been proved in the literature, researchers have proposed several improved versions to make SOS suitable for different optimization problems [32]. In this present study, an improved version of the standard version [19], called enhanced SOS algorithm (ESOS) that is equipped with a modification to the parasitism phase, is applied to set a better balance between exploration and exploitation and simultaneously improve the convergence rate of the basic SOS algorithm. The effective performance of the ESOS algorithm has been investigated for solving mathematical benchmark and structural engineering design problems [19]. Motivated by the success, the article will extend the ESOS algorithm for solving the optimization problems for damage assessment of full-scale structures.

#### Modifications on original parasitism phase:

The modified parasitism phase is mainly focused on saving computational cost but still maintaining the global ability in search space. In order to meet this objective, a sub-phase termed as “cleptoparasitism”, incorporated with the parasitism phase of the conventional SOS algorithm. The cleptoparasitism sub-phase is similar to that which was developed from crow search algorithm (CSA) [39]. This sub-phase simulates the ingenious behavior of crows in keeping their food’s hiding place, and is expressed in this article as follows:

$$X_{cleptoparasite}^{new} = X_{cleptoparasite} + coef(X_{best} - X_{cleptoparasite}) \quad (15)$$

where  $X_{cleptoparasite}$  is treated as a host to another organism;  $coef$  denotes the coefficient of the difference in value possessed by the

#### The commensalism phase:

Like mutualism activity, an organism  $X_k$  is randomly chosen from the ecosystem to interact with  $X_i$ . In the commensalism phase, the organism  $X_i$  attempts to get benefits from the interaction to improve its functional value. The mathematical formulation of the phase can be expressed as

$$X_i^{new} = X_i + rand(-1, 1) * (X_{best} - X_k) \quad (11)$$

where  $rand$  is a uniformly generated random number in the range  $[-1, 1]$ .

Finally, the selection operation is employed to choose individuals that give better fitness values to the next phase,

$$X_i = \begin{cases} X_i & \text{if } \Gamma(X_i) \leq \Gamma(X_i^{new}) \\ X_i^{new} & \text{otherwise} \end{cases} \quad (12)$$

#### The parasitism phase:

In this phase, an organism  $X_i$  from the ecosystem is randomly selected and then it creates an artificial parasite named as “parasite-vector” by duplicating  $X_i$  and modifying some randomly selected design variables within its bounds. Parasite-vector acts as a host to another organism  $X_k$  (where  $k \neq i, k \in (1, 2, \dots, Np)$ ), as shown by

$$X_{parasite,k} = \begin{cases} X_{i,k} & \text{if } rand(0, 1) \leq rand(0, 1) \\ X^l + rand * (X^u - X^l) & \text{otherwise} \end{cases} \quad (13)$$

Thereafter, the selection operation in this phase is given as

$$X_{i,j} = \begin{cases} X_{parasite,k} & \text{if } \Gamma(X_{parasite,k}) \leq \Gamma(X_{i,j}) \\ X_{i,j} & \text{otherwise} \end{cases} \quad (14)$$



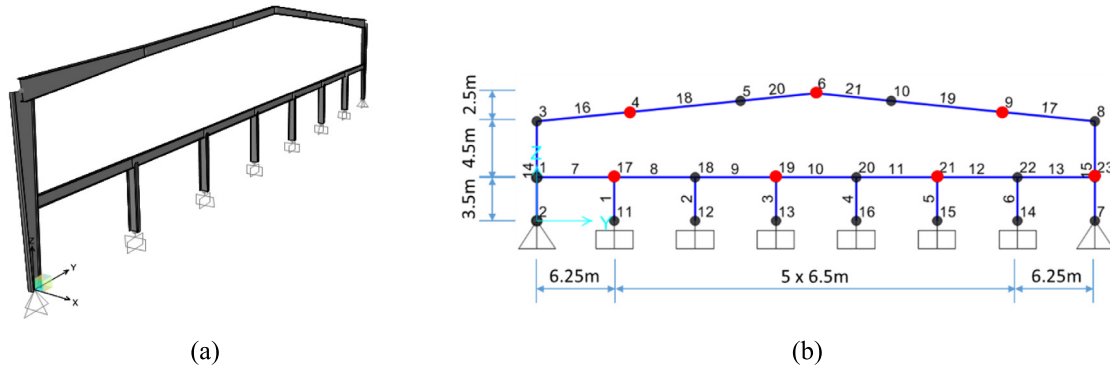

Fig. 3. (a) The FE model of industrial steel frame; (b) Node and element numbering of the FE model.

Table 1

The material properties and geometrical properties of all elements in the industrial steel frame.

Section types	Elements	Young's modulus (MPa)	Poisson's ratio	Mass density (kg/m <sup>3</sup> )
1500 × 165 × 10 × 6 × 185 × 10	1–6	206	0.3	7850
1500 × 250 × 14 × 8 × 250 × 14	7–13, 18–21			
I(900-400) × 250 × 14 × 8 × 250 × 14	16, 17			
I(900-500) × 250 × 14 × 8 × 250 × 14	14, 15			

Note: 1500 × 165 × 10 × 6 × 185 × 10 denotes I shape section with 500 mm height, 165 mm top flange width, 10 mm top flange thickness, 6 mm web thickness, 185 mm bottom flange width, and 10 mm bottom flange thickness; I(900-400) × 250 × 14 × 8 × 250 × 14 denotes I shape section with the height varied from 900 mm to 400 mm throughout its length.

Table 2

Five different damage scenarios in the industrial steel frame.

Scenario	Description	Damaged elements (reduction of stiffness)
A	Single damage on main frame column	14 (20%)
B	Double damage on column and beam	4 (20%) & 12 (30%)
C	Double damage at on main frame column and beam	14 (20%) & 16 (20%)
D	Double damage at two adjacent on main frame beam	16 (20%) & 18 (40%)
E	Multi-damage on frame	10 (15%) & 15 (20%) & 16 (40%) & 20 (20%)

highest degree of adaptation ( $X_{best}$ )

$$coef = rand(-1, 1) * fl \quad (16)$$

where  $fl$  denotes flight length determined by Askarzadeh [39]. In this study, the value of  $fl$  is set to 2.

As mentioned above, the modified parasitism phase comprises two sub-phases including the cleptoparasitism sub-phase and the original parasitism sub-phase. These two sub-phases should be chosen with one of the rates changing from 0.6/0.4 to 0.4/0.6. It is because a rate that is not too biased towards one side may gain a better balance between the exploitation and exploration capabilities. In this study, the chosen rate of two sub-phases is 0.6/0.4. In addition, we would like to note that choosing the rate of two sub-phases would directly affect the search performance of the ESOS algorithm, and hence the selection of a suitable rate should be based on specific problems. The pseudo-code of this phase can be described as:

```

if rand[0, 1] ≤ 0.6
    Generate parasite-vector (Eq. (13))
    Selection operation
else if
    Generate cleptoparasite-vector (Eq. (15))
    Selection operation
end if
    
```

(17)

It should be noted that the generation counter will be increased from  $G$  to  $G_{max}$  by repeating the three phases (mutualism,

commensalism, and modified parasitism phases) and simultaneously check for stopping criterion. After the search process terminates, the optimal solution to the studied optimization problem is identified. The flowchart of the FE model updating process based on SAP2000-OAPI and ESOS algorithm for damage assessment of full-scale structures is presented in Fig. 2.

#### 4. Numerical examples

In this part, the proposed FE model updating technique is utilized for damage detection and quantification of full-scale structures. Two numerical examples comprising an industrial steel frame and a 3D two-story full-scale building are carried out to illustrate the effectiveness and robustness of the proposed technique. For each example, various possible damage scenarios are examined with and without noise-polluted data. Structural damage is simulated by a local reduction of Young's modulus of selected members. It is assumed that the behavior of the monitored structures is linear before and after the existence of damage. Due to the stochastic nature of noisy conditions, five independent runs are performed for each damage scenario, and then the average results of damage diagnosis are reported. Control parameters of ESOS algorithm for both examples are given as:  $N_p = 30$ ,  $G_{max} = 300$ , and stop criterion =  $10^{-8}$ .

##### 4.1. An industrial steel frame

The first example considered is an industrial steel plane frame (45 m wide and 8 m high), as described in Fig. 3. The FE model

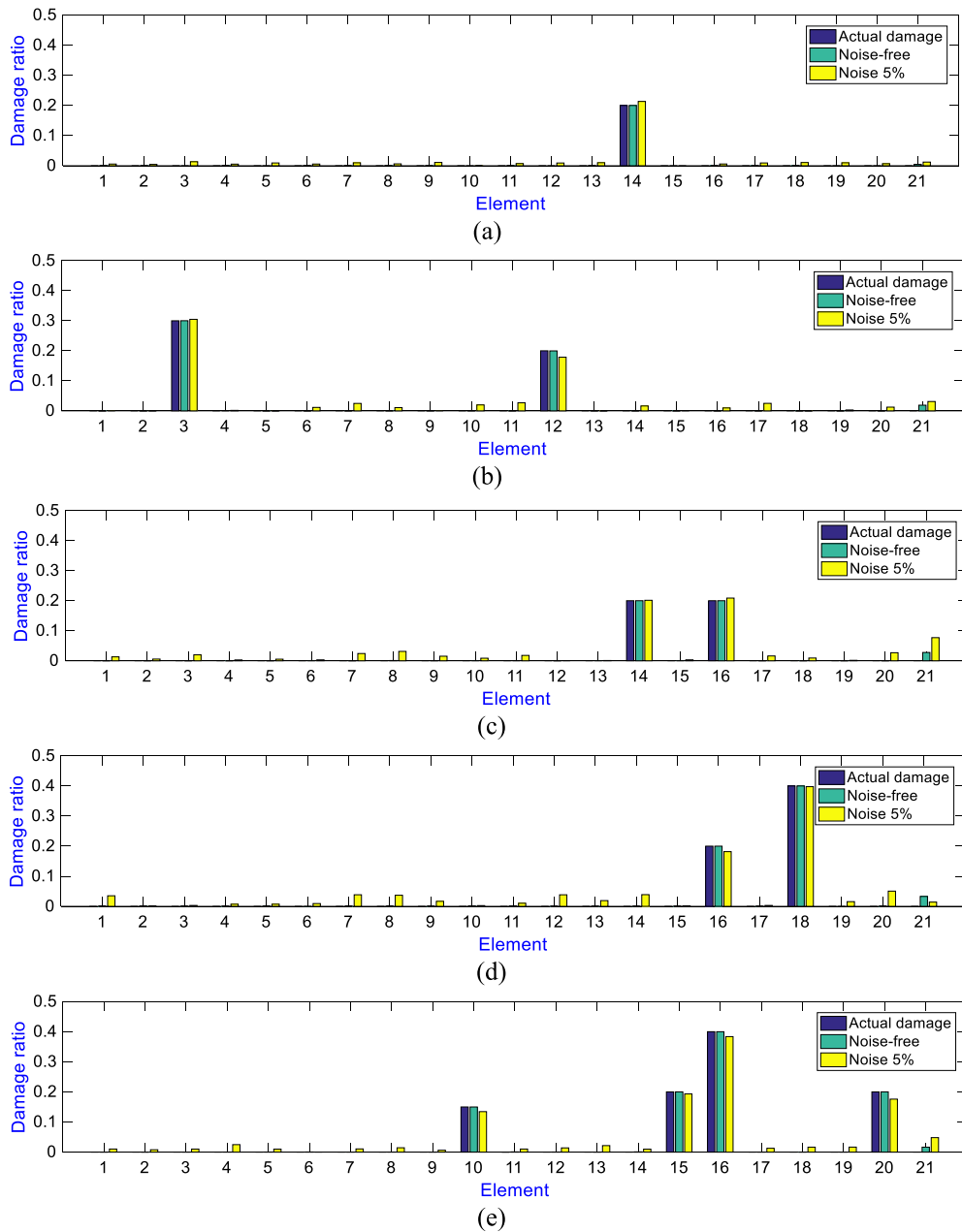

**Fig. 4.** Damage detection results for five damage scenarios of the industrial steel plane frame: (a) Scenario A; (b) Scenario B; (c) Scenario C; (d) Scenario D; (e) Scenario E.

of the industrial steel frame was constructed by using SAP2000 v16 commercial software, which consists of 21 elements with 23 nodes. The sections of main columns and beams are non-prismatic rigid frames varied throughout the length. The material properties and geometrical properties for all elements are shown in Table 1. Five different damage scenarios are considered for the steel frame and their details are described in Table 2. The last scenario, a multi-damage case with different severities, is represented as a more difficult situation to test the feasibility of the proposed FE model updating technique. For all scenarios, only the first five modes are utilized in both noise-free and noise-polluted data ( $\pm 1\%$  noise in natural frequencies and  $\pm 5\%$  noise in mode shapes). The first five free vibration frequencies of the steel plane frame calculated using SAP2000 v16 are 2.991, 3.382, 6.480, 9.603, and 13.004 Hz, respectively.

To deal with the problem of limited measurement data, a finite number of sensor measurements at nodes 4, 6, 9, 17, 19, 21, and

23 is assumed to be installed on the steel frame structure, which provides the partial mode shapes at measured 21 DOFs (degrees-of-freedom). The nodes highlighted with red circles in Fig. 3(b) represent the locations of measurement points.

The average results of identified damage ratios of 21 elements obtained by the proposed FE model updating technique for scenarios A to E are reported in Fig. 4(a) to (e), respectively. Overall, the results indicate that despite the effect of data incompleteness and measurement errors, all the sites of actually damaged elements in all hypothetical damage scenarios are correctly localized. It is also seen that the existence of noise in modal data causes to decrease the accuracy of identified results. Specifically, in the noise-free condition, the proposed technique produces both the location and severity of damage(s) with high accuracy. In the noise-polluted condition, there are a few false alarms (i.e., element 21 in scenario C; elements 20 in scenario D) with

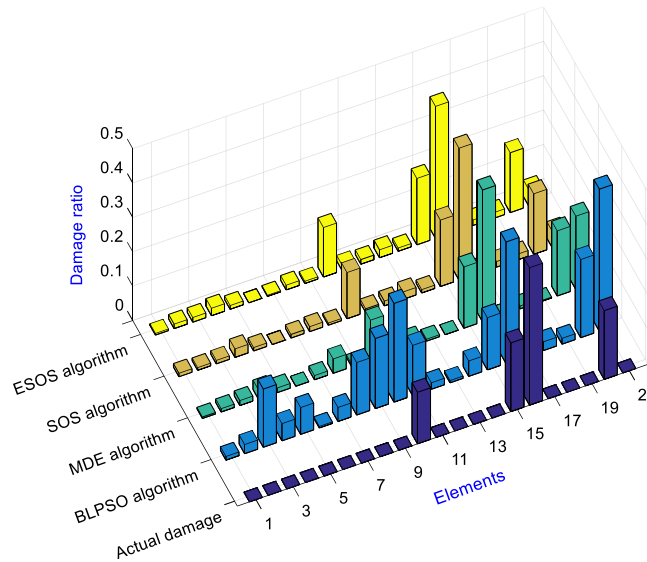

Fig. 5. Damage detection results for scenario E of the industrial steel plane frame using different optimization algorithms.

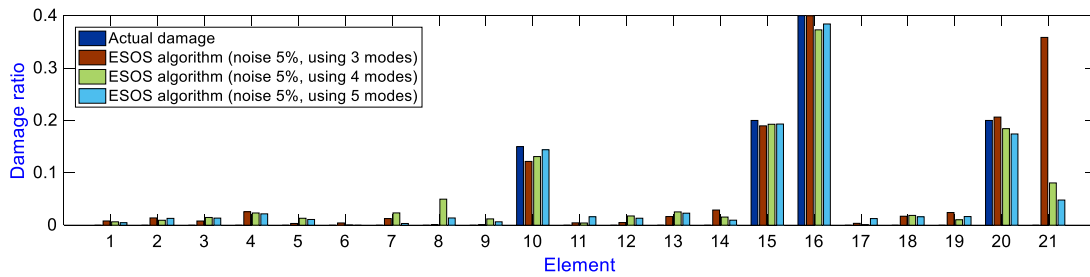

Fig. 6. Comparison of damage identification results for scenario E of the industrial steel plane frame with measurement noise (5%) using various modes.

small damage ratios, although it still maintains the acceptable accuracy of damage severity estimation.

To test the performance of the selected optimizer for solving the model-updating-based damage detection problem, the results given by ESOS algorithm are compared with those obtained by biogeography-based learning particle swarm optimization (BLPSO) [40], modified differential evolution (MDE) algorithm [13], and SOS algorithm. For this purpose, the four optimization algorithms are applied to scenario E (multi-damage case) considering the incomplete measured data with noise (5%). According to Fig. 5, the poor damage detection and many large false errors result from the BLPSO algorithm and one large false alarm occurs in element 21 when using the MDE algorithm. Meanwhile, both the SOS and ESOS algorithms correctly localize the actually damaged elements and have almost the same accuracy for damage identification in the steel frame structure. Further, Table 3 provides the statistical results of structural damage identification from the SOS and ESOS algorithms in 5 independent runs. From the table, one can find that the mean values of elemental stiffness reductions obtained by these two optimization methods are quite similar. In particular, for the noise-free case, the mean error of SOS and ESOS algorithm are 0.05% and 0.15%, respectively, while those for the noisy case are 7.45% and 6.05%, respectively. Also, the standard deviation of the predicted results is relatively small. Nevertheless, in terms of computational effort, the ESOS algorithm uses the lower number of structural analyses compared with the original SOS algorithm. These comparison results demonstrate the computational efficiency of selected optimizer for solving the problem.

To further illustrate the validity of the proposed damage identification technique in measurement situations, the influences of

measurement noise levels and numbers of selected modes on its accuracy are also studied. First, to bring a thorough view on the selection of the modes for damage identification with measurement noise (5%), the proposed method is carried out on damage scenario E using the first three, four and five modes measured from the measurement points. According to Fig. 6, the number of used modes has a significant influence on the accuracy of the proposed method. In this case, it is found that better estimation results are obtained when the number of considered modes increases progressively to five. Then, different noise levels are considered here by adding  $\pm 7\%$  or  $10\%$  instead of  $\pm 5\%$  noise in mode shapes (1% noise in natural frequencies is fixed). The bar plot in Fig. 7 shows the average value of evaluated damage severity for scenario E with the three noise levels (5%, 7%, and 10%). As can be seen from the figure, although the average identified damage extents are still close to the true values, the proposed method has a few false alarms elements (elements 8 and 21) appeared in its predictions. This result implies that a further increase in measurement noise level from 5% to 10% results in the reduction of accuracy of identification results in this case.

#### 4.2. A 3D two-story full-scale building

In the second example, we consider a 3D two-story full-scale building, 12 m long, 6 m wide, and 7 m high. The building has a concrete slab at each floor level and the thickness of each plate is 120 mm. The material properties and geometrical properties of the building structure are tabulated in Table 4. A 3D FE model of the structure is undertaken using SAP2000 v16 commercial software, as shown in Fig. 8. The concrete plate is modeled with

**Table 3**

The statistical results of SOS and ESOS algorithms for damage scenario E of the industrial steel plane frame.

Scenario	Noise level	Actual location	Assumed value	SOS algorithm			ESOS algorithm		
				Avg. value	Std. Dev	Avg. NSA	Avg. value	Std. Dev	Avg. NSA
E	0%	$x_{10}$	0.15	0.1504	0.0014	1956	0.1499	0.0009	1464
		$x_{15}$	0.2	0.1998	0.0001		0.2001	0.0002	
		$x_{16}$	0.4	0.3997	0.0004		0.3999	0.0003	
		$x_{20}$	0.2	0.2003	0.0003		0.2001	0.0002	
	5%	$x_{10}$	0.15	0.1345	0.0169	2394	0.1441	0.0163	1842
		$x_{15}$	0.2	0.1932	0.0104		0.1932	0.0108	
		$x_{16}$	0.4	0.3837	0.0216		0.3841	0.0202	
		$x_{20}$	0.2	0.1760	0.0204		0.1742	0.0214	

Avg. value = average value of stiffness reduction factor; Std. Dev = standard deviation; Avg. NSA = an average number of structural analyses.

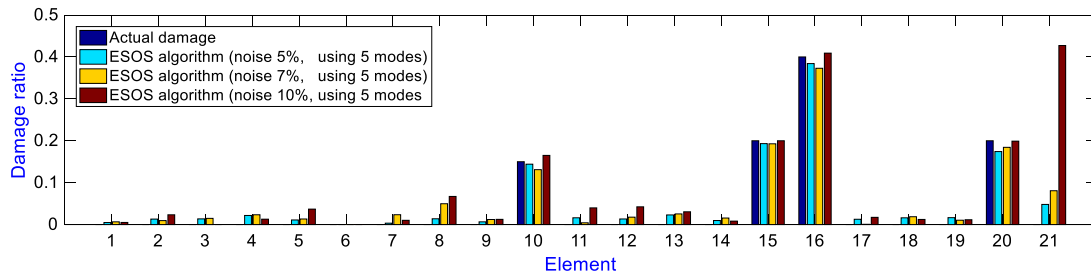
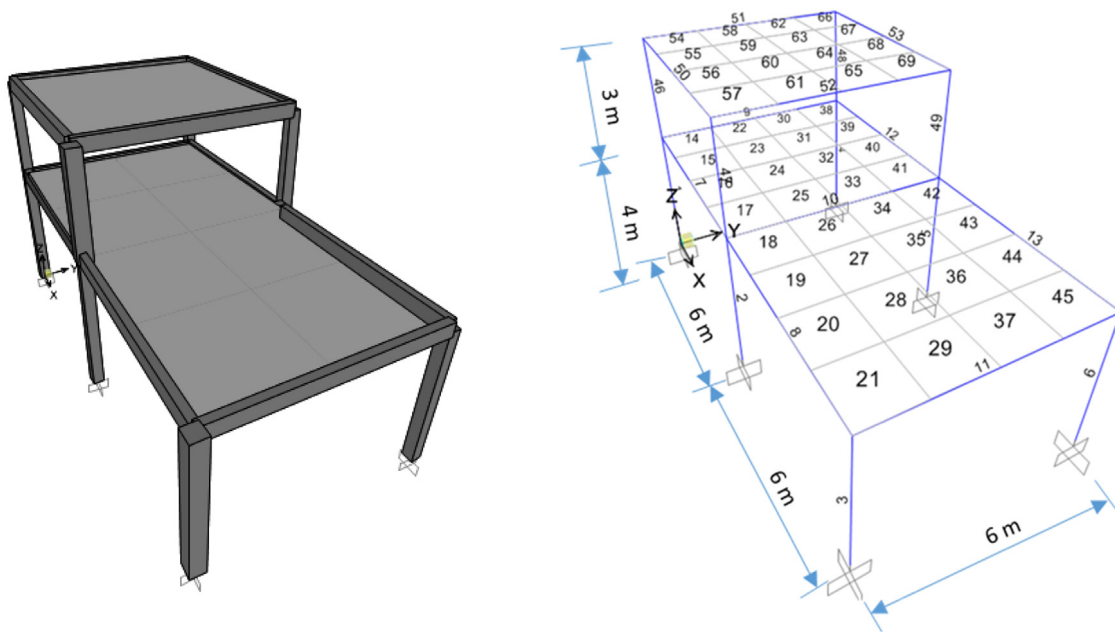
**Fig. 7.** Comparison of damage identification results for scenario E of the industrial steel plane frame using the first five modes with measurement noise levels.**Fig. 8.** The FE model of 3D two-story full-scale building and its element numbering.

thin shell elements, whereas frame elements are employed for columns and beams. In total, the SAP2000 modeled building comprises 48 shell elements, 21 frame elements, and 76 nodes. To investigate the feasibility of the developed technique, six different damage scenarios are considered and listed in Table 5. In this example, it is also assumed that only the first five modes are available for structural damage detection. The first five natural frequencies of the building structure calculated using SAP2000 v16 are 0.861, 1.885, 2.774, 3.008, and 4.513 Hz, respectively. Fig. 9 displays the first five vibration modes of the simulated building structure.

To deal with the incompleteness conditions of measured modal data, a set of selected sensors at 23 nodes are installed to provide the partial mode shapes. Fig. 10 highlights the locations of these

measurement points on the plan view of the building. So, the updating process will use these 138 DOFs information to predict damage locations and their severities.

Employing the proposed FE model updating technique, the final structural damage detection results are shown in Fig. 11(a) to (f) for scenarios A to F, respectively. It is evident from the figures that overall, all the true damaged positions are correctly identified. Particularly, in the case of spatially-incomplete measurements with noise-free data, the proposed technique succeeds in both localization and damage quantification with high precision. In the case of spatially-incomplete measurements with noise-polluted data, although several undamaged elements are falsely detected especially for multi-damage scenario F, it is still



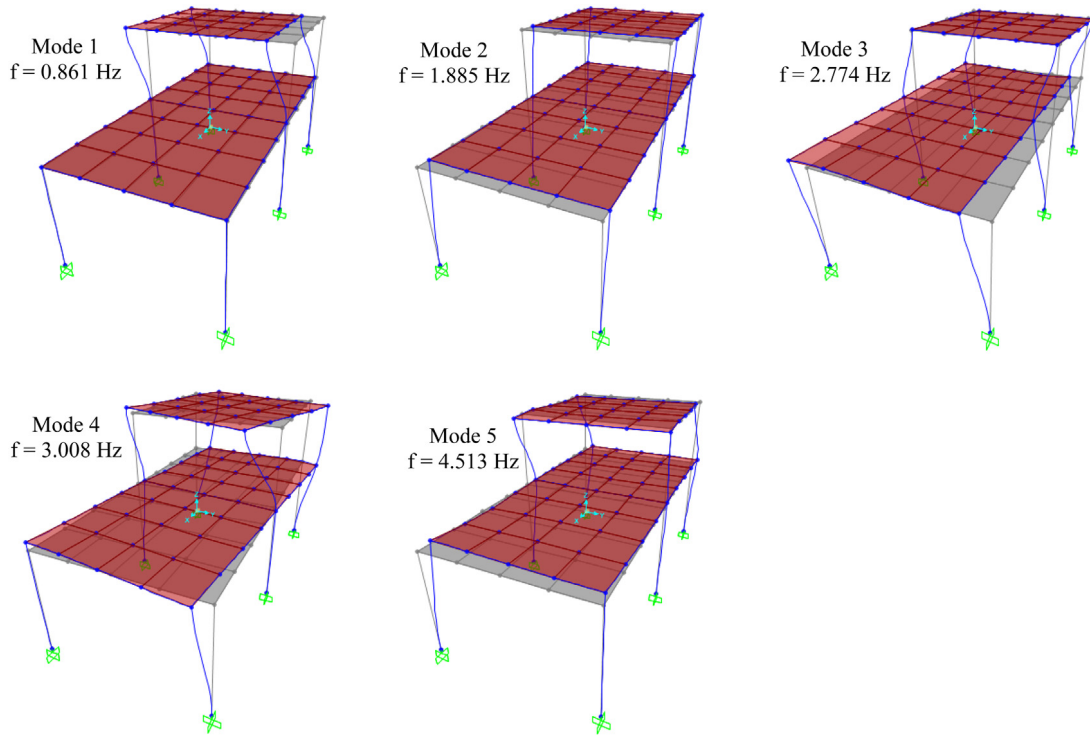

Fig. 9. The first five vibration modes of the simulated building structure.

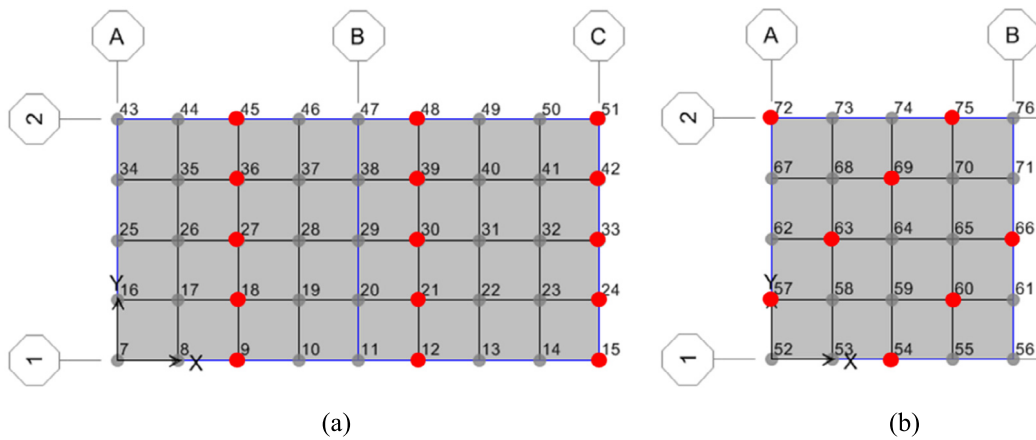

Fig. 10. Sensor layout on 3D two-story full-scale building: (a) first floor; (b) second floor.

Table 4

The material properties and geometrical properties of all elements in the 3D two-story full-scale building.

Section types	Elements	Young's modulus (MPa)	Poisson's ratio	Mass density (kg/m <sup>3</sup> )
C 300 × 300	2-5, 46-49	35	0.2	2500
C 400 × 400	1, 6			
B 200 × 400	7-9, 11 – 13, 50 – 53			
B 300 × 500	10			
F 120	14-45, 54-69			

Note: C 300 × 300 denotes the column section with 300 mm width and 300 mm height; B 200 × 400 denotes the beam section with 200 mm width and 400 mm height; F 120 denotes the thickness of floor slabs is 120 mm.

effective to localize the actually damaged elements and approximately estimate their severities. These presented results also emphasize the impact of measurement errors on the success of the FE model updating process.

Further, to illustrate our statement about the efficiency of the selected optimization algorithm, the impairment assessment

results of the ESOS algorithm for scenario F are compared to those from the basic SOS algorithm in Table 6. This table presents the statistical results comprising the mean values, standard deviation and number of structural analyses of both the optimization algorithms for scenario F. Again, the comparative results indicate that both the ESOS and basic SOS algorithms produce similar damage

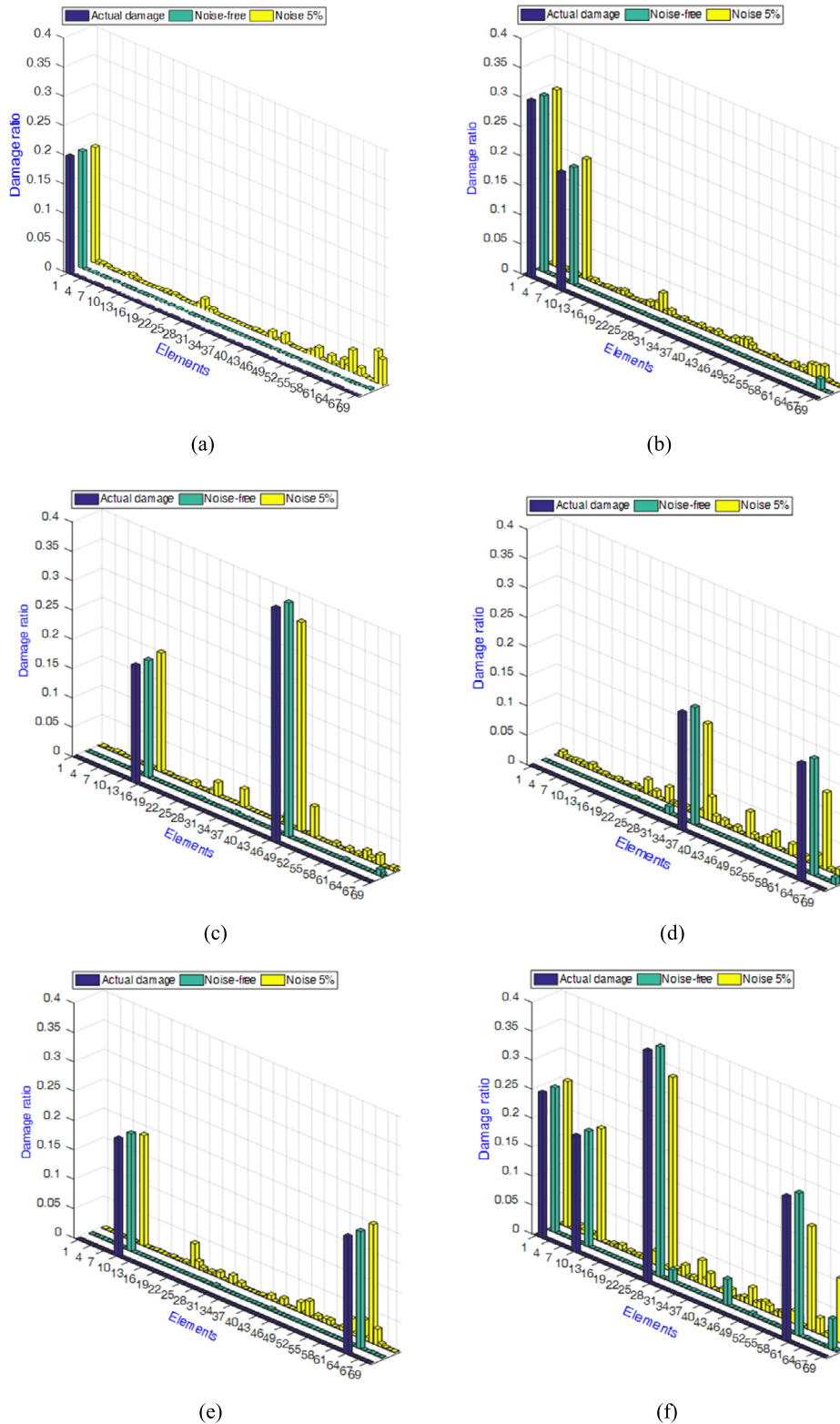

Fig. 11. Damage detection results for six damage scenarios of the two-story full-scale building: (a) Scenario A; (b) Scenario B; (c) Scenario C; (d) Scenario D; (e) Scenario E; (f) Scenario F.

detection outcomes. However, in view of the computational cost, the ESOS requires a less number of structural analyses to reach the optimum solution than the SOS.

### 5. Conclusions

The article presents an optimization-based FE model updating technique coupled with a commercial software package for

**Table 5**  
Six different damage scenarios in the 3D two-story full-scale building.

Scenario	Description	Damaged elements (reduction of stiffness)
A	Single damage on column	1 (20%)
B	Double damage on column and beam	2 (30%) & 9 (20%)
C	Double damage on floor and column	15 (20%) & 47 (40%)
D	Double damage on floor (stories 1 and 2)	36 (20%) & 64 (20%)
E	Triple damage at on beam and floor	10 (20%) & 64 (20%)
F	Multi-damage on column, beam, floor	2 (25%) & 10 (20%) & 27 (40%) & 60 (25%)

**Table 6**  
The statistical results of SOS and ESOS algorithms for damage scenario 3 of the two-story full-scale building.

Scenario	Noise level	Actual location	Assumed value	SOS algorithm			ESOS algorithm		
				Avg. value	Std. Dev	Avg. NSA	Avg. value	Std. Dev	Avg. NSA
F	0%	$x_2$	0.25	0.2498	0.0014	2790	0.2502	0.0002	1416
		$x_{10}$	0.2	0.1992	0.0001		0.1996	0.0003	
		$x_{27}$	0.4	0.3995	0.0004		0.3977	0.0016	
		$x_{60}$	0.25	0.2445	0.0003		0.2466	0.0042	
	5%	$x_2$	0.25	0.2436	0.0200	5850	0.2518	0.0063	3900
		$x_{10}$	0.2	0.1885	0.0166		0.1949	0.0098	
		$x_{27}$	0.4	0.3072	0.0632		0.3361	0.0779	
		$x_{60}$	0.25	0.2083	0.1015		0.1799	0.1088	

Avg. value = average value of stiffness reduction factor; Std. Dev = standard deviation; Avg. NSA = an average number of structural analyses.

damage assessment of full-scale structures. The current study exploits the commercial software SAP2000 as a slave program for FE analysis and an enhanced symbiotic organisms search (ESOS) algorithm as a powerful optimization solver for finding the optimal solution of FE model updating problem. The ESOS algorithm coded in MATLAB is studied in conjunction with SAP2000 v16 through OAPI feature for two-way data exchange during the optimization process. Numerical investigations are carried out for an industrial steel frame and a 3D two-story full-scale building with different hypothetical damage cases, which enable us to draw the following conclusions

- The ESOS algorithm is computationally efficient compared to the basic SOS algorithm due to using less number of structural analyses. Therefore, this ESOS algorithm is highly recommended for the purpose of incorporating with FE model updating.
- Only the first five measured incomplete modes that are employed to calculate the objective function are sufficient to solve the damage detection problems successfully.
- Even under spatially-incomplete measurements and a relatively high level of noise, the proposed damage diagnosis technique can reliably produce the detection of true damage locations and the prediction of damage magnitudes with an acceptable level of accuracy.
- The proposed FE model updating technique is successful in the integration of a commercial FE modeling software with a custom research software, which significantly steers the use of modern technology for damage assessment of full-scale structures. Such a technique can be potentially developed and applied to real SHM systems. It should be pointed out that in real conditions, the operational and environmental fluctuations such as temperature, wind, and humidity will lead to negatively affect the performance of the proposed technique. Thus, before applying the proposed technique to real-world structures, it is essential to study how well this technique works under different effects of these factors.

#### Declaration of competing interest

No author associated with this paper has disclosed any potential or pertinent conflicts which may be perceived to have

impending conflict with this work. For full disclosure statements refer to <https://doi.org/10.1016/j.asoc.2020.106100>.

#### Acknowledgment

This research is funded by Vietnam National Foundation for Science and Technology Development (NAFOSTED) under Grant number 107.02-2019.330.

#### References

- [1] B. Moaveni, S. Hurlbaas, F. Moon, Special issue on real-world applications of structural identification and health monitoring methodologies, *J. Struct. Eng.* 139 (2013) 1637–1638, [http://dx.doi.org/10.1061/\(ASCE\)ST.1943-541X.0000779](http://dx.doi.org/10.1061/(ASCE)ST.1943-541X.0000779).
- [2] S. Nagarajaiah, K. Erazo, Structural monitoring and identification of civil infrastructure in the United States, *Struct. Monit. Maint.* 3 (2016) 51–69, <http://dx.doi.org/10.12989/smm.2016.3.1.051>.
- [3] A. Alvandi, C. Cremona, Assessment of vibration-based damage identification techniques, *J. Sound Vib.* 292 (2006) 179–202, <http://dx.doi.org/10.1016/j.jsv.2005.07.036>.
- [4] Y.J. Yan, L. Cheng, Z.Y. Wu, L.H. Yam, Development in vibration-based structural damage detection technique, *Mech. Syst. Signal Process.* 21 (2007) 2198–2211, <http://dx.doi.org/10.1016/j.ymsp.2006.10.002>.
- [5] S. Das, P. Saha, S.K. Patro, Vibration-based damage detection techniques used for health monitoring of structures: a review, *J. Civ. Struct. Heal. Monit.* 6 (2016) 477–507, <http://dx.doi.org/10.1007/s13349-016-0168-5>.
- [6] M. Pedram, A. Esfandiari, Mitigating the effect of incomplete measurement in sensitivity-based FE model updating by enhanced transfer function, *Iran. J. Sci. Technol. Trans. Civ. Eng.* 6 (2018) <http://dx.doi.org/10.1007/s40996-018-0180-6>.
- [7] D. Dinh-Cong, T. Vo-Duy, T. Nguyen-Thoi, Damage assessment in truss structures with limited sensors using a two-stage method and model reduction, *Appl. Soft Comput.* 66 (2018) 264–277, <http://dx.doi.org/10.1016/j.asoc.2018.02.028>.
- [8] N.F. Alkayem, M. Cao, Y. Zhang, M. Bayat, Z. Su, Structural damage detection using finite element model updating with evolutionary algorithms: a survey, *Neural Comput. Appl.* 30 (2018) 389–411, <http://dx.doi.org/10.1007/s00521-017-3284-1>.
- [9] D. Dinh-Cong, S. Pham-Duy, T. Nguyen-Thoi, Damage detection of 2D frame structures using incomplete measurements by optimization procedure and model reduction, *J. Adv. Eng. Comput.* 2 (2018) 164–173, <http://dx.doi.org/10.25073/jaec.201823.203>.
- [10] D.-C. Du, H.-H. Vinh, V.-D. Trung, N.-T. Hong Quyen, N.-T. Trung, Efficiency of Jaya algorithm for solving the optimization-based structural damage identification problem based on a hybrid objective function, *Eng. Optim.* 50 (2018) 1233–1251, <http://dx.doi.org/10.1080/0305215X.2017.1367392>.

- [11] D. Dinh-Cong, T. Pham-Toan, D. Nguyen-Thai, T. Nguyen-Thoi, Structural damage assessment with incomplete and noisy modal data using model reduction technique and LAPO algorithm, *Struct. Infrastruct. Eng.* 15 (2019) 1436–1449, <http://dx.doi.org/10.1080/15732479.2019.1624785>.
- [12] Z.H. Ding, M. Huang, Z.R. Lu, Structural damage detection using artificial bee colony algorithm with hybrid search strategy, *Swarm Evol. Comput.* 28 (2016) 1–13, <http://dx.doi.org/10.1016/j.swevo.2015.10.010>.
- [13] D. Dinh-Cong, T. Vo-Duy, V. Ho-Huu, H. Dang-Trung, T. Nguyen-Thoi, An efficient multi-stage optimization approach for damage detection in plate structures, *Adv. Eng. Softw.* 112 (2017) 76–87, <http://dx.doi.org/10.1016/j.advengsoft.2017.06.015>.
- [14] N.F. Alkayem, M. Cao, Damage identification in three-dimensional structures using single-objective evolutionary algorithms and finite element model updating: evaluation and comparison, *Eng. Optim.* 50 (2018) 1695–1714, <http://dx.doi.org/10.1080/0305215X.2017.1414206>.
- [15] Z. Chen, L. Yu, A new structural damage detection strategy of hybrid PSO with Monte Carlo simulations and experimental verifications, *Measurement* 122 (2018) 658–669, <http://dx.doi.org/10.1016/j.measurement.2018.01.068>.
- [16] G.F. Gomes, Y.A.D. Mendez, P. da Silva Lopes Alexandrino, S.S. da Cunha, A.C. Anceletti, A review of vibration based inverse methods for damage detection and identification in mechanical structures using optimization algorithms and ANN, *Arch. Comput. Methods Eng.* 4 (2018) 1–15, <http://dx.doi.org/10.1007/s11831-018-9273-4>.
- [17] S.-S. Jin, H.-J. Jung, Sequential surrogate modeling for efficient finite element model updating, *Comput. Struct.* 168 (2016) 30–45, <http://dx.doi.org/10.1016/j.compstruc.2016.02.005>.
- [18] E. Simoen, G. De Roeck, G. Lombaert, Dealing with uncertainty in model updating for damage assessment: A review, *Mech. Syst. Signal Process.* 56 (2015) 123–149, <http://dx.doi.org/10.1016/j.ymsp.2014.11.001>.
- [19] M.-Y. Cheng, D. Prayogo, Symbiotic organisms search: A new metaheuristic optimization algorithm, *Comput. Struct.* 139 (2014) 98–112, <http://dx.doi.org/10.1016/j.compstruc.2014.03.007>.
- [20] J.R. Nayak, B. Shaw, B.K. Sahu, Application of adaptive-SOS (ASOS) algorithm based interval type-2 fuzzy-PID controller with derivative filter for automatic generation control of an interconnected power system, *Eng. Sci. Technol. Int. J.* 21 (2018) 465–485, <http://dx.doi.org/10.1016/j.jestch.2018.03.010>.
- [21] M. Sedighzadeh, M. Esmaili, A. Eisapour-Moarref, Hybrid symbiotic organisms search for optimal fuzzified joint reconfiguration and capacitor placement in electric distribution systems, *Ina. Lett.* 2 (2017) 107–121, <http://dx.doi.org/10.1007/s41403-017-0029-5>.
- [22] D.C. Secui, A modified symbiotic organisms search algorithm for large scale economic dispatch problem with valve-point effects, *Energy* 113 (2016) 366–384, <http://dx.doi.org/10.1016/j.energy.2016.07.056>.
- [23] Y. Sonmez, H.T. Kahraman, M.K. Dosoglu, U. Guvenc, S. Duman, Symbiotic organisms search algorithm for dynamic economic dispatch with valve-point effects, *J. Exp. Theor. Artif. Intell.* 29 (2017) 495–515, <http://dx.doi.org/10.1080/0952813X.2016.1198935>.
- [24] D.T.T. Do, J. Lee, A modified symbiotic organisms search (mSOS) algorithm for optimization of pin-jointed structures, *Appl. Soft Comput. J.* 61 (2017) 683–699, <http://dx.doi.org/10.1016/j.asoc.2017.08.002>.
- [25] G.G. Tejani, V.J. Savsani, V.K. Patel, S. Mirjalili, Knowledge-based systems truss optimization with natural frequency bounds using improved symbiotic organisms search, *Knowl.-Based Syst.* (2017) 1–17, <http://dx.doi.org/10.1016/j.knsys.2017.12.012>.
- [26] D. Dinh-Cong, T. Nguyen-Thoi, M. Vinyas, D.T. Nguyen, Two-stage structural damage assessment by combining modal kinetic energy change with symbiotic organisms search, *Int. J. Struct. Stab. Dyn.* 19 (2019) 1950120, <http://dx.doi.org/10.1142/S0219455419501207>.
- [27] N. Dib, A. Amaireh, A. Al-Zoubi, On the optimal synthesis of elliptical antenna arrays, *Int. J. Electron.* 106 (2019) 121–133, <http://dx.doi.org/10.1080/00207217.2018.1512658>.
- [28] N. Dib, Design of linear antenna arrays with low side lobes level using symbiotic organisms search, *Prog. Electromagn. Res. B* 68 (2016) 55–71, <http://dx.doi.org/10.2528/PIERB16032504>.
- [29] V.F. Yu, A.A.N.P. Redi, C.L. Yang, E. Ruskartina, B. Santosa, Symbiotic organisms search and two solution representations for solving the capacitated vehicle routing problem, *Appl. Soft Comput. J.* 52 (2017) 657–672, <http://dx.doi.org/10.1016/j.asoc.2016.10.006>.
- [30] S. Vinoth, G. Kanimozhi, H. Kumar, E.S. Srinadhu, N. Satyanarayana, Symbiotic organism search algorithm for simulation of J-V characteristics and optimizing internal parameters of DSSC developed using electrospun TiO<sub>2</sub> nanofibers, *J. Nanopart. Res.* 19 (2017) <http://dx.doi.org/10.1007/s11051-017-4071-8>.
- [31] F. Miao, Y. Zhou, Q. Luo, A modified symbiotic organisms search algorithm for unmanned combat aerial vehicle route planning problem, *J. Oper. Res. Soc.* 70 (2019) 21–52, <http://dx.doi.org/10.1080/01605682.2017.1418151>.
- [32] A.E. Ezugwu, D. Prayogo, Symbiotic organisms search algorithm: theory, recent advances and applications, *Expert Syst. Appl.* 119 (2019) 184–209, <http://dx.doi.org/10.1016/j.eswa.2018.10.045>.
- [33] M. Abdullahi, M.A. Ngadi, S.I. Dishing, S.M. Abdulhamid, M.J. Usman, A survey of symbiotic organisms search algorithms and applications, *Neural Comput. Appl.* 4 (2019) <http://dx.doi.org/10.1007/s00521-019-04170-4>.
- [34] F.S. Gharehchopogh, H. Shayanfar, H. Gholizadeh, A Comprehensive Survey on Symbiotic Organisms Search Algorithms, Springer, Netherlands, 2019, <http://dx.doi.org/10.1007/s10462-019-09733-4>.
- [35] D. Prayogo, F.T. Wong, S. Sugianto, Enhanced symbiotic organisms search (ESOS) for global numerical optimization, in: *Proceeding - ICAMIMIA 2017 Int. Conf. Adv. Mechatronics, Intell. Manuf. Ind. Autom.*, 2018, pp. 69–73, <http://dx.doi.org/10.1109/ICAMIMIA.2017.8387560>.
- [36] M. Sanayei, P. Rohela, Automated finite element model updating of full-scale structures with PARAMeter Identification System (PARIS), *Adv. Eng. Softw.* 67 (2014) 99–110, <http://dx.doi.org/10.1016/j.advengsoft.2013.09.002>.
- [37] A. Nozari, I. Behmanesh, S. Yousefianmoghdam, B. Moaveni, A. Stavridis, Effects of variability in ambient vibration data on model updating and damage identification of a 10-story building, *Eng. Struct.* 151 (2017) 540–553, <http://dx.doi.org/10.1016/j.engstruct.2017.08.044>.
- [38] D. Dinh-Cong, T. Vo-Duy, V. Ho-Huu, T. Nguyen-Thoi, Damage assessment in plate-like structures using a two-stage method based on modal strain energy change and Jaya algorithm, *Inverse Probl. Sci. Eng.* 27 (2019) 166–189, <http://dx.doi.org/10.1080/17415977.2018.1454445>.
- [39] A. Askarzadeh, A novel metaheuristic method for solving constrained engineering optimization problems: Crow search algorithm, *Comput. Struct.* 169 (2016) 1–12, <http://dx.doi.org/10.1016/j.compstruc.2016.03.001>.
- [40] X. Chen, B. Xu, W. Du, An improved particle swarm optimization with biogeography-based learning strategy for economic dispatch problems, *Complexity* 2018 (2018) 1–15, <http://dx.doi.org/10.1155/2018/7289674>.